

ASPIRAZIONE TRUCIOLI RETTIFICA  
ASPIRATION WOOD CHIPS MILLING UNIT

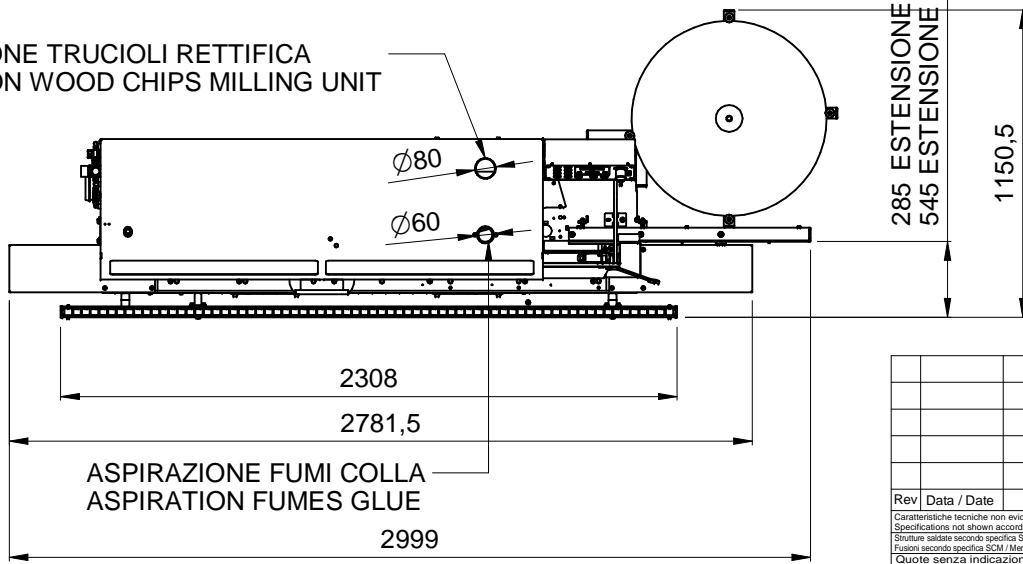

ASPIRAZIONE FUMI COLLA  
ASPIRATION FUMES GLUE

ALLACCIAMENTO ARIA COMPRESSA / AIR CONNECTION

ALLACCIAMENTO LINEA ELETTRICA / ELECTRICAL CONNECTION

ASPIRAZIONE / ASPIRATION:  
V=20m/sec  
Qtot=1330m³/h  
ARIA COMPRESSA / AIR:  
Pressione d'alimentazione / pressure network 8-10bar  
Consumo d'aria / consumption air: ~600NL  
POTENZA INSTALLATA / POWER:  
In= 18 A  
Pn= 5.5 Kw

Rev	Data / Date	Firma / Signature	Descrizione ultima modifica / Last change description	N° Modifica / Change ID
<small>Caratteristiche tecniche non evidenziate secondo istruzioni operative SCM GROUP : IO 23/1DTG            Specifications not shown according to SCM GROUP operation instruction            Struttura assistita secondo specifica SCM / Welded according to SCM specific : ST232DTG            Fusione secondo specifica SCM / Mergens second SCM specific : ST233DTG</small>				Verniciatura / Painting ( SCM specific ST231DTG ) Superficie / Surface (m²) <b>VER000</b>
Quote senza indicazione di tolleranza, grado di precisione Shares without indication of tolerance, accuracy			<b>SCM Specifica ST2310DTG</b> Trattamento Superficiale / Surface Treatment ( SCM specific ST234DTG )	
Ultimo rilascio / Latest release		Rugosità / Roughness*		Trattamento Termico / Heat Treatment ( SCM specific ST234DTG )
Controllato / Checker		<b>CF3</b> 0 Smussi / chamfer		Peso grezzo/Raw weight (kg) Massa / Mass (kg) <b>36576521,49</b> <b>Vedi Nota</b>
Disegnato / Designed		<b>M.Gabrielli</b> <b>07/03/2016</b>		Materiale / Material ( SCM specific ST235DTG )
<b>scm group</b>				
Denominazione / Item Name <b>ME28 T DISTINTA APERTA GENERALE</b>			Scala / Scale <b>1:20</b>	Codice / Item ID <b>90L0365815B</b>
			Rev <b>00</b>	Status <b>1/1</b>

© RISERVIAMO I TERMINI DI LEGGE LA PROPRIETA' DI QUESTO DISEGNO CON DIVIETO DI RENDERSLO COMA QUOTE A TERZI SENZA LA NOSTRA PREVENTIVA APPROVAZIONE. / THIS DRAWING IS SCM PROPERTY. COPYRIGHTED MATERIAL. DISCLOSURE TO THIRD PARTIES WITHOUT OUR AUTHORISATION IS EXPLICITLY FORBIDDEN.